

Ref: **1005.96901**

ISTRUZIONI DI MONTAGGIO - MOUNTING INSTRUCTIONS

Adattabile a – Suitable to : COS. ME Actros MP4 Big / Giga space

Visiera	1 pcs	2. Staffa principale	2 pcs
3. Tappo vite	10 pcs	4. Collare di copertura	10 pcs
5. Vite M6x25mm	10 pcs	6. Rondella in gomma 6mm	10 pcs
7. Rondella in gomma 3mm	8 pcs	8. Vite M6x20mm	20 pcs
9. Rondella M6x18mm	2 pcs	10. Dado M6	8 pcs
11. Inserto M6	20 pcs	12. Guarnizione	20 pcs
13. Staffa centrale	1 pair	14. Staffa laterale	1 pair
Acrylic part	1 pcs	2. Main bracket	2 pcs
3. Cover hat	10 pcs	4. Cover collar	10 pcs
5. Screw M6x25mm	10 pcs	6. Rubber washer 6mm	10 pcs
7. Rubber washer 3mm	8 pcs	8. Hex screw M6x20mm	20 pcs
9. Washer M6x18mm	2 pcs	10. Nylok M6	8 pcs
11. Rivet nut M6	20 pcs	12. Rubber gasket	20 pcs
13. Center bracket	1 pair	14. Side bracket	1 pair

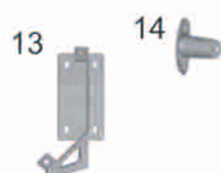
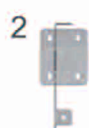
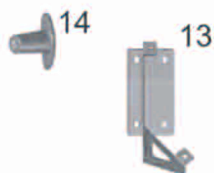

Montare la parte acrilica sulle staffe come mostrato nel disegno: quando si monta la staffa laterale non si utilizzano le parti 9 e 10.

Mount the acrylic part on brackets as shown on the drawing: when you mount the side bracket you do not use parts 9 and 10.

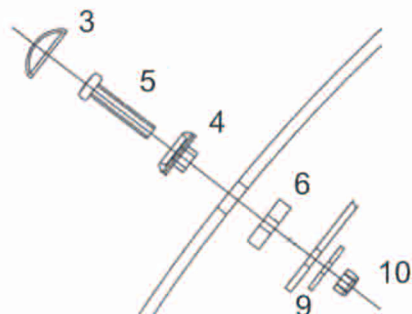

Posizionare la visiera sul tetto del veicolo e segnare la posizione dei fori. Praticare i fori con una punta da 4,0 mm. Ora praticate i fori per i dadi dei rivetti alla dimensione di 9,0 mm con uno strumento di perforazione a gradini. Si prega di notare che il foro deve essere stretto per il dado del rivetto. Sikaflex sui fori e monta i dadi per rivetti come mostrato nel disegno.

Place the visor on the vehicles roof and mark the hole positions. Drill the holes with 4.0mm bit. Now drill the holes for the rivet nuts to size of 9.0mm with a step drill tool. Please note that the hole must be tight for rivet nut. But Sikaflex on the holes and mount the rivet nuts as shown on the drawing.

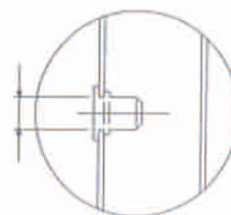

Montare la visiera sul tetto come mostrato nel disegno.

Mount the visor on the roof as shown on the drawing.

